



The Flying Fifteen Association of Ireland



Sailing Instructions - Flying Fifteen Frostbites, 2025 National Yacht Club, Dun Laoghaire Commencing Saturday, 18th October, 2025

1. RULES

- 1.1. The series will be governed by the rules as defined in The Racing Rules of Sailing (RRS) and by the rules and prescriptions of the ISA.
- 1.2. The rules of the Flying Fifteen Class will apply, insofar as they do not conflict with the Notice of Race or the Sailing Instructions.
- 1.3. The Sailing Instructions may also change other racing rules.
- 1.4. The Organizing Authority is the National Yacht Club.

2. NOTICES TO COMPETITORS

- 2.1. Notices to competitors will be posted on the official notice board located at the National Yacht Club, on the wall beneath the balcony.

3. CHANGES TO SAILING INSTRUCTIONS

- 3.1. Any change to the sailing instructions will be posted before 10:00 on the day it will take effect, except that any change to the schedule of races will be posted by 20:00 on the day before it will take effect.

4. ADVERTISING

- 4.1. Boats shall display advertising supplied by the organizing authority as required.

5. SIGNALS MADE ASHORE

- 5.1. Signals made ashore will be displayed on the main yardarm of the National Yacht Club.
- 5.2. When ICF 'AP' is displayed ashore, '1 minute' is replaced with 'not less than sixty minutes' in the RRS Race Signals documentation.

6. VHF

- 6.1. All boats shall carry a VHF radio.
- 6.2. On the water, the race committee will monitor and communicate with competitors on VHF radio channel 69.
- 6.3. The following radio communications may be made by the race committee: the location of the starting area, countdown to the start, general recalls, listing black-flag DSQs and postponements. Failure to make these broadcasts or failure to hear them shall not constitute grounds for redress. This changes rule 62.1.

- 6.4. Except in an emergency, a boat shall neither make radio transmissions while racing nor receive radio communications not available to all boats. This restriction also applies to mobile telephones.

7. SCHEDULE

- 7.1. Ten races are scheduled as follows:

Date	Warning Gun	Number of Races
Sat 18 th October	13:00	2
Sat 25 th October	13:00	2
Sat 1 st November	13:00	2
Sat 8 th November	13:00	2
Sat 15 th November	13:00	2

- 7.2. The warning signal for each succeeding race will be made as soon as practicable after the completion of the previous race.
- 7.3. The Race Officer may choose to run additional races and will indicate such by (a) displaying the ICF 'E' on the committee boat at the finish of the last scheduled race and (b) by announcing this on VHF.

8. CLASS FLAG + RACING AREA

- 8.1. The class flag will be ICF Naval '6'.
- 8.2. The racing area shall be the waters of Dublin Bay.

9. THE COURSES

- 9.1. The diagrams in Appendix A show the courses, the order in which marks are to be rounded, and the side on which each mark is to be left.
- 9.2. Course T, Sausage-Triangle-Sausage, will be signaled by displaying ICF 'T' together with one of ICF '1', '2' or '3'.
- 9.3. Course W, Windward-Leeward, will be signaled by displaying ICF 'W' together with one of ICF '1', '2' or '3'.
- 9.4. The Race Committee may display the approximate compass bearing to Mark 1.

10. THE START

- 10.1. Races will be started by using Rule 26 with the warning signal made five minutes before the starting signal.
- 10.2. The starting line will be between a red and white pole or the main mast on the committee boat at the starboard end and the course side of the port end outer distance mark or an orange pole on an outer distance rib.
- 10.3. To alert the class that a starting sequence is about to commence an Orange Warning Signal may be displayed from the committee boat no less than five minutes before the display of the first warning signal.
- 10.4. A boat starting later than ten minutes after her starting signal will be scored Did Not Start (DNS) without a hearing. This changes Rules A3 and A5.

11. CHANGING OR SHORTENING THE COURSE

- 11.1. To change the next leg of the course, the race committee will move the original mark or a new mark (or the finishing line) to a new position. Minor changes will not be signaled.
- 11.2. In addition to RRS 32.2, if a rib at a mark displays ICF 'F' with repeated sound signals, then all boats, having rounded that mark between the rib and the mark, shall sail directly from that mark to the finish line and finish the race by crossing the line from the direction of the last mark. This changes RRS 28.

12. THE FINISH

- 12.1. The finishing line will be between a red and white pole or the main mast on the committee boat and an outer distance mark.

13. TIME LIMITS

- 13.1. If no boat has passed Mark 1 within thirty minutes of her start, the race will be abandoned.
- 13.2. Boats failing to finish within fifteen minutes after the first boat sails the course and finishes will be scored Did Not Finish (DNF) without a hearing. This changes Rules 35, A3, A4 and A5.

14. PROTESTS

- 14.1. Protests and request for redress shall be made to the Race Officer within one hour of the last competitor finishing the race.
- 14.2. RRS, Appendix T Arbitration, will apply with the following changes:
 - The arbitrator may be a member of the panel at the protest hearing subsequent to an arbitration meeting.
 - When the arbitrator decides that Rule 44.1(b) does not apply and that arbitration is appropriate, if party is not present at the arbitration meeting any party that was present may take a Post-Race Penalty at any time until the Protest Committee has completed taking evidence.
- 14.3. Notices of protests by the race committee or protest committee will be posted to inform boats under Rule 61.1(b).
- 14.4. Breaches of items 16, 19, 20 or 22 in these Sailing Instructions will not be grounds for a protest by a boat. This changes Rule 60.1(a). Penalties for these breaches lie at the discretion of the protest committee. Any Discretionary Penalty Imposed will be abbreviated DPI.
- 14.5. On the last scheduled day of racing a request for redress based on a protest committee decision shall be delivered no later than thirty minutes after the decision was posted. This changes Rule 62.2.

15. SCORING

- 15.1. The Race Officer will apply the RRS Appendix A4 'LOW POINT SYSTEM'.
- 15.2. Two races are required to be completed to constitute a series.
- 15.3. When three or less races have been completed, a boat's series score will be the total of her race scores.
- 15.4. When 4 to 7 races have been completed, the boat's series score will be the total of her race scores excluding her worst score.

- 15.5. When eight or more races have been completed, the boat's series score will be the total of her race scores excluding her two worst scores.

16. SAFETY REGULATIONS

- 16.1. A boat that retires from a race or returns to harbour before the completion of that day's scheduled races shall notify the race committee as soon as possible.
- 16.2. At all times, boats shall keep clear of commercial shipping.

17. REPLACEMENT OF COMPETITORS

- 17.1. Substitution of competitors will not be allowed without prior written approval of the race committee.

18. PENALTY SYSTEM

- 18.1. RRS 44.1 is changed so that the Two-Turns Penalty is replaced by the One-Turn Penalty.

19. EQUIPMENT AND MEASUREMENT CHECKS

- 19.1. Each boat shall have a valid measurement certificate and each boat shall use sails certified as class-compliant by a class-approved measurer.
- 19.2. Each boat shall comply with the DLFFF's safety equipment list.
- 19.3. The Race Committee, or an official appointed by it, may inspect competing boats at any time.

20. TRASH DISPOSAL

- 20.1. Boats shall not put rubbish in the water and must keep it aboard the boat until it returns ashore, where the rubbish can be disposed of appropriately.

21. DISCLAIMER OF LIABILITY

- 21.1. Competitors participate in the series entirely at their own risk. See RRS 3, 'Decision to Race'. The organizing authority will not accept any liability for material damage, personal injury or death sustained in conjunction with, or prior to, during, or after, the series.

22. INSURANCE

- 22.1. Each participating boat shall be insured with valid third-party liability insurance with a minimum cover of €3,000,000 per event or the equivalent in another currency. *This will be confirmed by competitors in the online entry form.*

1. Appendix A, Courses

- 1.1. The series will take place on courses which are either Sausage-Triangle-Sausage or Windward-Leeward.
- 1.2. For all courses:
- Marks 1, 2 and 3 will be large yellow or orange inflatable marks.
 - Mark W will be an orange inflatable mark or Dan buoy type mark.
 - The starting and finishing Mark P, will be a distinctive Dan buoy with a flag or an inflatable orange mark or a rib with an orange flag.
- 1.3. Diagrams in this appendix are not to scale and do not indicate the absolute or relative lengths or angles of the legs. The committee boat is labelled 'CB' below.
- 1.4. The committee boat will indicate a Sausage-Triangle-Sausage course by displaying ICF 'T' together with one of ICF '1', '2' or '3' to indicate a course as follows:

T1	1 – W – 3 – finish
T2	1 – W – 3 – 1 – 2 – 3 – finish
T3	1 – W – 3 – 1 – 2 – 3 – 1 – W – 3 – finish

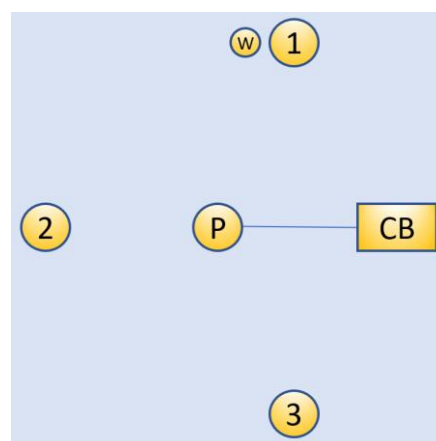

- 1.5. The committee boat will indicate a Windward-Leeward course by displaying ICF 'W' together with one of ICF '1', '2' or '3' to indicate a course as follows:

W1	1 – W – 2 – finish
W2	1 – W – 2 – 1 – W – 2 – finish
W3	1 – W – 2 – 1 – W – 2 – 1 – W – 2 – finish

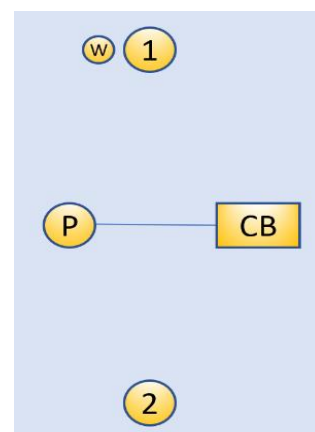

- 1.6. The Race Officer may, at their discretion, choose not to lay an offset mark (W). In such cases, competitors will round the windward mark and proceed directly to the next designated mark.